

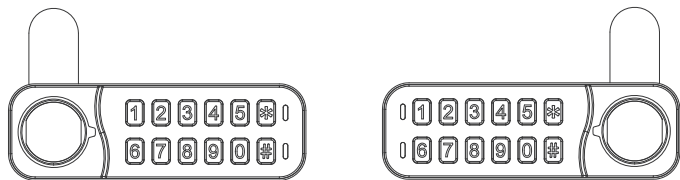

"VIC" ELECTRONIC KEYPAD LOCK

Installation Guide

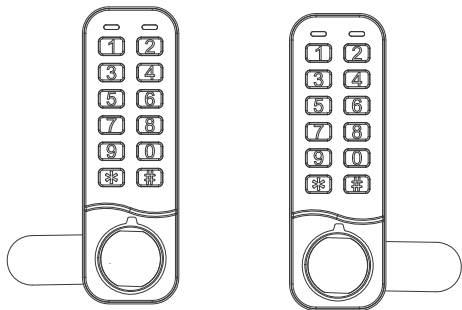
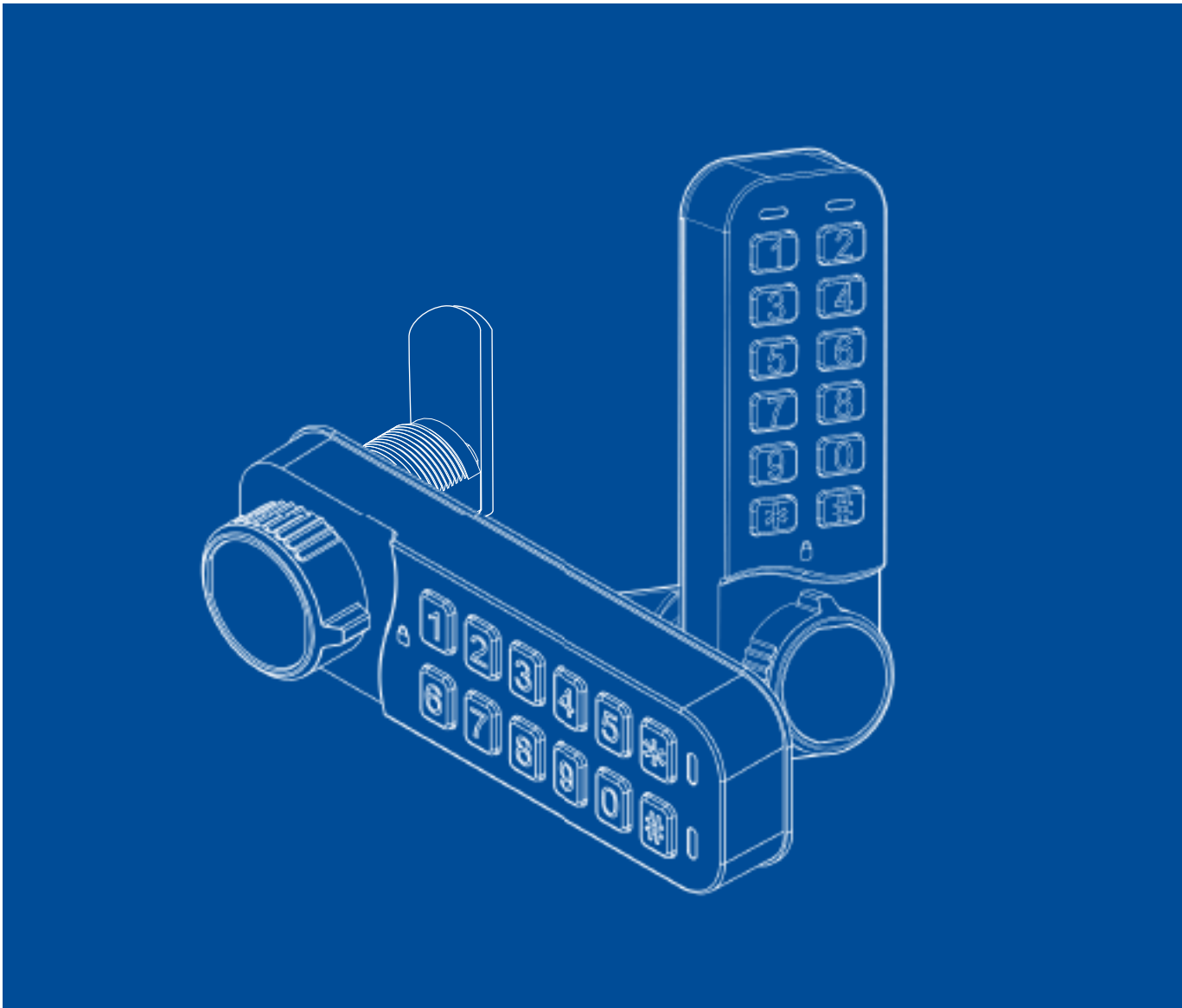

Installation Procedure

1. Lock Body

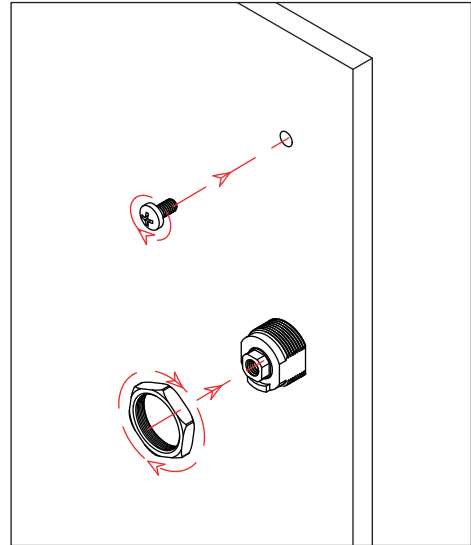
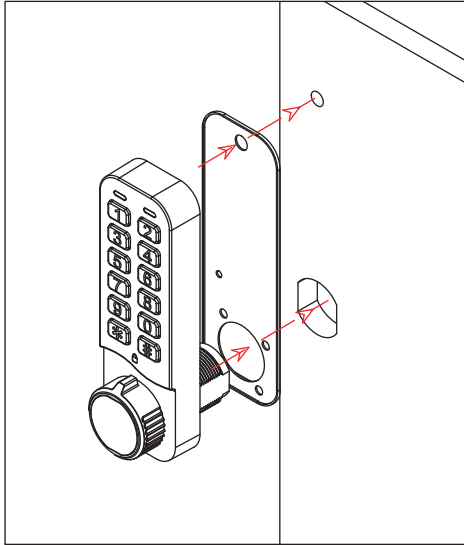

3. Cam

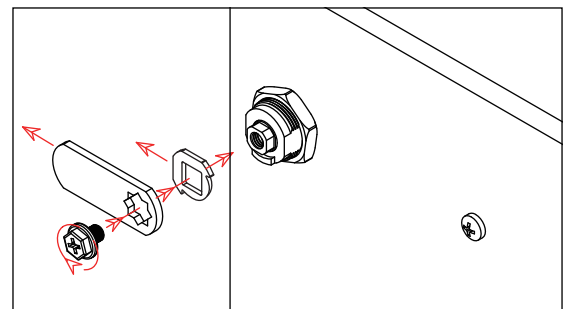
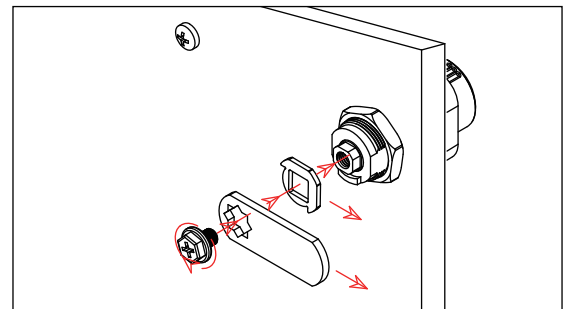
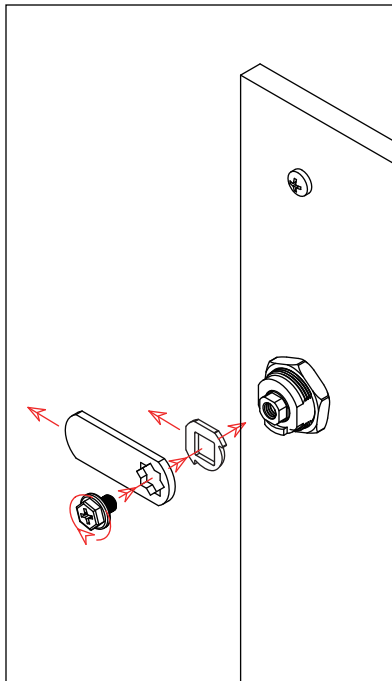
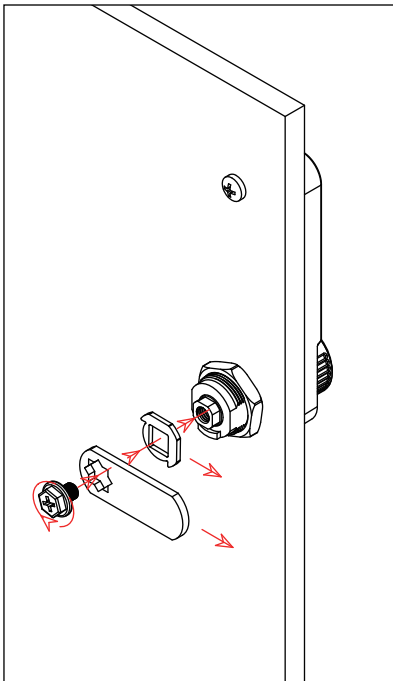

Installation Hole

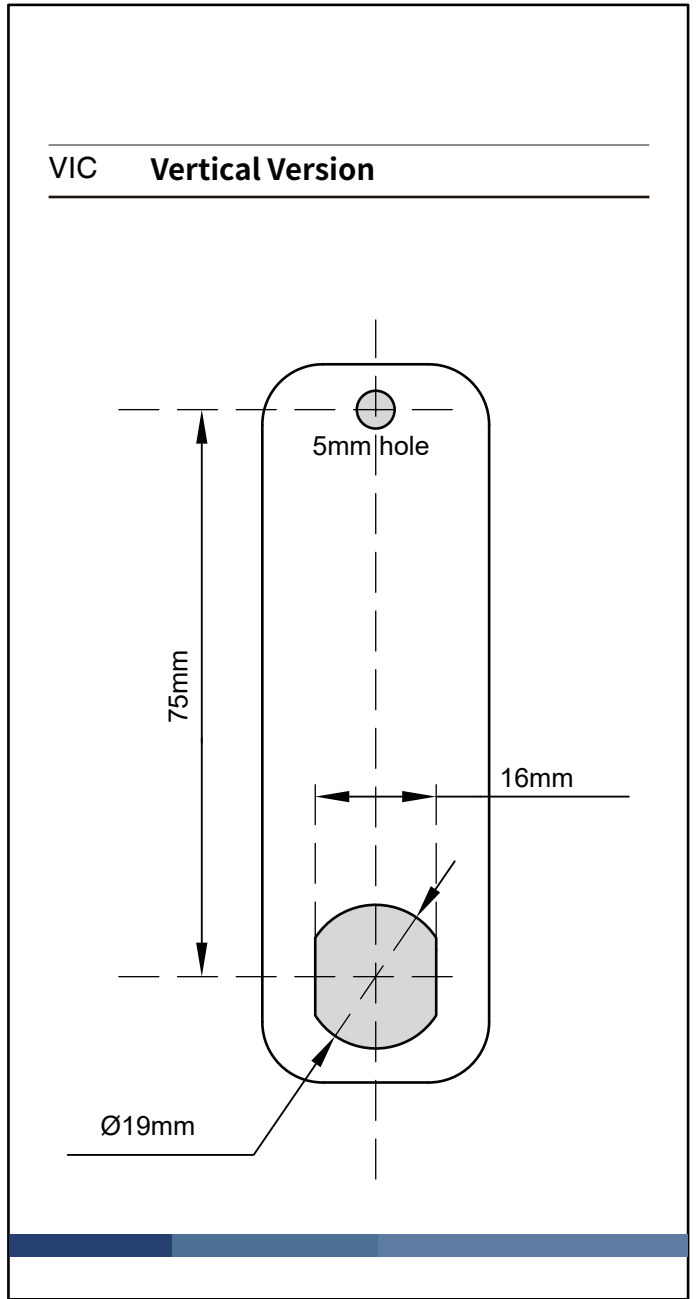
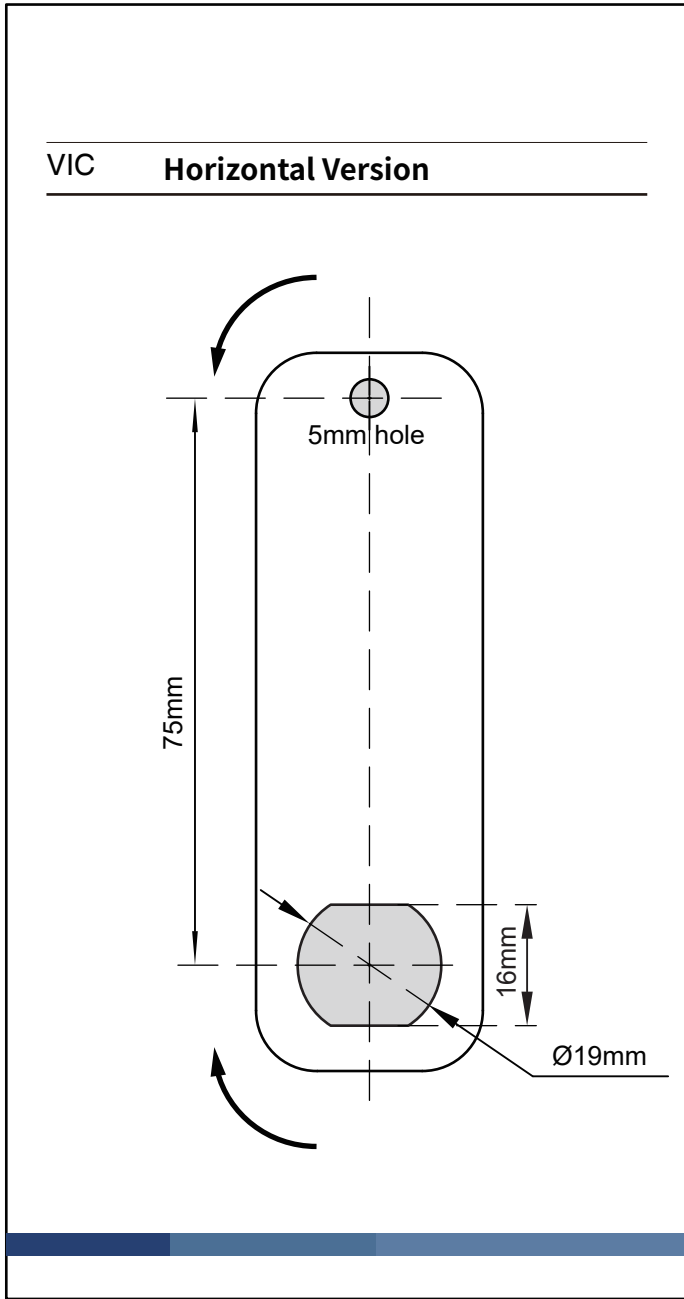

Battery Change

1. Take off the Cam

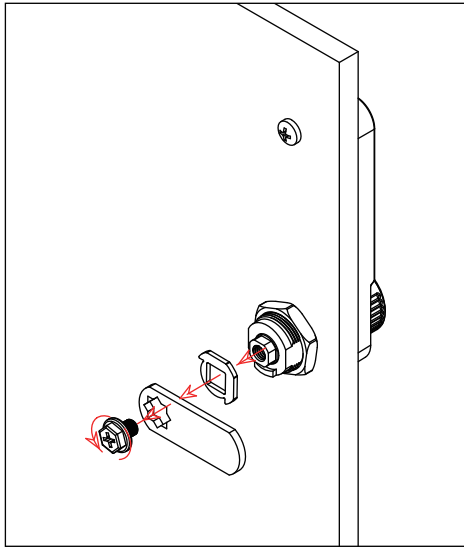

2. Take off the nut

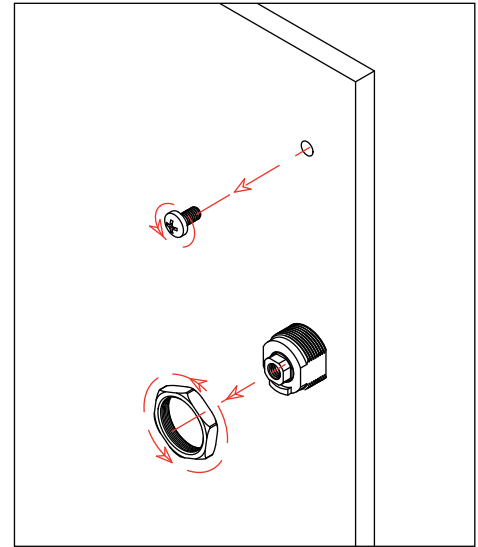

3. Take out the battery cover and battery

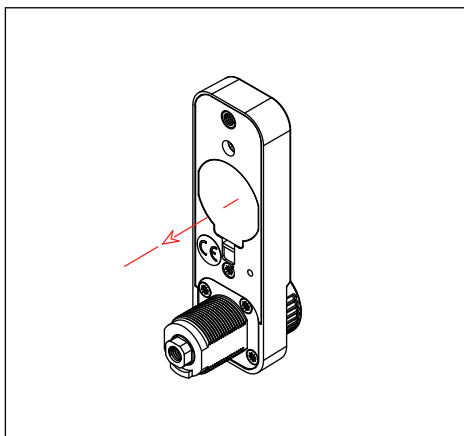

4. Change new battery

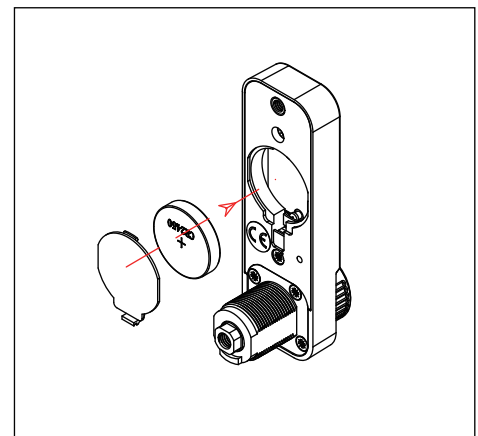

IMPORTANT!!!

CR2450 battery with minimum 590 mAh is to be used
(Energizer or Panasonic is recommended)